

# **SB3 trailer**

## **guidelines for use** **and service**

**Please read carefully.**

**The information provided is a guide to the use of your trailer. The information is from the NTTA and AL- KO web sites.**

## IMPORTANT INFORMATION

**By following the advice and recommendations, you will do much to reduce the devastating effects of water, particularly salt water, but cannot guarantee that problems will not occur.**

It is recommended that hubs and brakes are not immersed in water, particularly salt water, but if they are, then the following advice can be offered:

- A. **DO NOT immerse when the hub is hot i.e. Straight after a long journey, but wait until the assembly has cooled, otherwise a vacuum will be created, making the ingress of water even worse.**
- B. Keep immersion times to the very minimum and **DO NOT** leave the trailer standing in the water after the boat has been launched.
- C. After immersion in salt water, the hub assembly and indeed the whole trailer should be thoroughly hosed down with fresh water. AL - KO recommend taking one wheel stud nut out and flushing the drum through the hole into the drum whilst rotating the wheel after immersion in salt water.
- D. Do not park the trailer for prolonged periods with the handbrake fully on, particularly when the hub is wet. If necessary, chock the wheels.
- E. It is recommended that the trailer is serviced more regularly than otherwise would be the case and certainly at **least every 3 months irrespective of mileage**. This must include a brake strip down and checking of bearings.
- F. Hubs with unitised bearings cannot be greased and whilst they are more resistant to the ingress of water, particularly if allowed to cool before immersion, they are **NOT** waterproof. Repeated immersion in water will eventually lead to their failure.
- G. Bowden cables generally are not provided with a lubrication medium i.e. A grease nipple, as the introduction of grease will inhibit the movement of the inner cable within the specially designed and coated outer casing. There is also a very real danger of excess grease contaminating the brake linings thus rendering them ineffective. Practical experience shows that a periodic soaking in thin oil e.g. WD 40, particularly over the winter months goes a long way towards avoiding seizure problems.
- H. Whenever the road wheel is removed and refitted, the wheel bolts should be torqued 55lbs/74nm in sequence north, south, east, west and rechecked after 50kms.

## Matching the Trailer with the Towing Vehicle

It is important that the vehicle you use to pull your trailer is adequate for the job

- Check that the engine is large enough to tow the trailer and load.
- Check that the brakes are powerful enough to stop the vehicle and trailer safely.
- Check that the Trailer Gross Weight does not exceed the Towing Capacity of the Towing vehicle.

The addition of a loaded trailer to a vehicle will inevitably have a very serious effect on the vehicle's performance. Starting, particularly on hills, can be much more laboured; stopping can take longer distances; cornering and negotiating sharp bends requires extra care.

Consider all these things very carefully when loading and towing your trailer. The most important check is the vehicle manufacturer's recommended towing limit, which should be in vehicle manufacturer's handbook and on the VIN plate on the chassis.

A good rule of thumb, for safety and stability, when towing , is the 85% figure recommended for caravans by the Caravan Club. This suggests that you should not tow a trailer that weighs more than 85% of the towing vehicle's kerb weight. (as long as 85% does not exceed the vehicle manufacturer's recommended towing limit. (The kerb weight is defined as the weight of the vehicle plus a full tank of petrol and 75kg (for the driver and luggage).)

Police Forces use the manufacturer's recommended towing limit as their guide. Under no circumstances should the vehicle's gross train weight be exceeded.

## **Trailer Checks before each journey**

The trailer operator or the driver of the towing vehicle, if different, has the responsibility for the safe operation of the trailer and needs to carry out the following checks:

- If the trailer is laden is the load correctly distributed i.e. Not too much or too little nose weight?
- Is the load within the trailer's official payload? - i.e. Not overloaded.
- Is the actual gross weight being towed within the towing vehicle manufacturer's recommended maximum towing limit (whether braked or unbraked.)?
- Is the load correctly secured?
- Are all the lights undamaged and working correctly?
- Are the 7 core cable and plug undamaged?
- Is the correct number plate fitted? (both registration number and style)
- Is the breakaway cable or secondary coupling undamaged and correctly connected, to a suitable point on the tow bar or towing vehicle?
- Are the tyre pressures correct and all tyres free from cuts, bulges and with adequate tread, (including the spare)? Tyres must have a continuous tread depth of at least 1.60 mm on cars, light vans and trailers, across the centre three-quarters of the width (1mm for other vehicles)
- Are you satisfied that the wheel nuts/bolts are tightened to the correct torque?
- If required are the mudguards in satisfactory condition and secure?
- Is the trailer correctly coupled to the towball or pin?
- Is the coupling height correct? I.e. Not excessively nose down or nose up.

### **Follow the golden rules of towing:**

- Make sure the trailer is level when coupled to the towing vehicle
- Make sure the nose weight is between 50 and 100kg (unless trailer is very light.)
- Make sure the tyre pressures are correct.
- Are the jockey wheel and any corner steadies or prop stands fully wound up and secure?

**NB.** Check the correct operation of damper and brakes as soon as possible after commencement of journey.

## Frequency of Servicing

This very much depends on type and frequency of usage, but an outline guide could be as follows:

- Daily or before each journey - certain checks are essential for safety and are the responsibility of the trailer operator.
- After the first 600 miles (1000 km) - essential for new trailers or if new brake linings and/or bowden cables are fitted.
- **Every 3000 miles (5000 km) - three monthly for commercial / industrial trailers intensive usage, either by mileage towed or type of application and including boat trailers that are immersed in water.**
- Every 6000 miles (10,000kms) - annually for caravans and leisure trailers. Six monthly for commercial/industrial trailers - based on "average" use.

**It is recommended that a suitable qualified person carries out the service.**

**See [www.al-ko.co.uk](http://www.al-ko.co.uk) for your nearest AL- KO service centre.**

## Overrun Coupling - Inspection & Service

- Overrun capacity** - check that it is correct for the gross weight of the trailer.
- Coupling mounting bolts** - check for tightness.
- Coupling head bolts** - check for tightness.
- Coupling head** - using a 50mm test towball (to meetBSAU 113c it must be between 49.61mm and 50.00mm) check that it locates and locks correctly in the coupling head and that any wear/location indicators are functioning. Lubricate the mechanism and lightly grease inside the coupling socket. N.B. If fitted with a 50mm coupling head type stabiliser, DO NOT GREASE.
- Draw tube** - check, by moving the shaft up and down, that the bearings that support the draw tube are not worn. The amount of end float between the shaft and the brake lever that is acceptable varies between manufacturers and should be checked in their service instructions
- Drawtube gaiter** - check for splits and tears. Replace if damaged.
- Damper** - with the handbrake off and wheels chocked, push the coupling in. If it does not move or goes in with no resistance and does not push itself back out, it must be worn and should be replaced. It should move in steadily with uniform resistance. **N.B.** it is essential that the correct specification of replacement damper is used and that manufacturers' fitting instructions are followed.
- Handbrake** - check the action for correct movement. If it is a ratchet type, are the condition and action of the teeth and pawl OK? Lubricate the pivots, including any grease nipples underneath.
- Grease nipples** - apply a grease gun to nipples on top of the housing, ensuring that a liberal amount of grease is applied.
- Breakaway cable** - check for kinks, fraying, operation of the clip and that the cable is securely attached to the "burst" ring. If replacement is required, ensure that a genuine part is used. It is desirable that the cable passes through a hole or guide in the front of the chassis to ensure straight line pull in the event of a breakaway.

- K. **Reverse cut out lever** - if the coupling is fitted with a self-correcting reverse cut out lever, check that it returns satisfactorily after being applied. The above are general outline procedures and reference should always be made to the specific coupling manufacturer's maintenance instructions.

## Brake Drum, Hub & Backplate Assembly

**Important Note:** If the coupling has an over centre style handbrake it is ESSENTIAL that the lever is tied down and the locking pins or stop pegs fitted as per the manufacturer's instructions, BEFORE any dismantling of the braking system is undertaken.

There are two types of hub available today - the older style drum utilising taper roller bearings and the more recent type with integral, unitised, sealed for life, non-adjustable bearings, which are used.

- A. **Trailer** - Jack up the trailer; support it on axle stands. Check for lateral bearing play by grasping wheel/tyre assembly at top and bottom and rocking. If adjustment or replacement is required, proceed to ( D ) below.
- B. **Wheels** - Remove road wheels.
- C. **Brake linings** - if possible check condition via inspection holes in back plate. If OK, proceed to ( L ) below. If unable to inspect via this method proceed to ( D ) below and remove brake drum.
- D. **Grease/dust cap** - remove to reveal castellated nut (taper roller) or flange nut (unitised bearing).
- E. **Split pin** - remove; undo castellated nut; remove thrust washer, if fitted and withdraw brake drum c/w bearings. With unitised bearings there is no split pin and the drum/bearing unit can be removed after undoing the "one shot" flange nut, which may take considerable effort. **N.B.** it maybe necessary to back off the brake adjustment to facilitate easy drum removal.
- F. **Unitised bearing/hub units** - There is no maintenance capability with these units and replacement may require specialised pressing equipment.
- G. **Brake drums** - inspect inner, sweep surface for rust and excessive scoring and check all surfaces for cracks and other damage.
- H. **Brake back plate** - clean out all dust with brake cleaner.
- I. **Brake springs** - examine for rust and/or breakage. Replace if necessary, noting position of all parts before stripping down.
- J. **Shoe carrier and expander** - check that they can slide freely. If not, clean and smear with small amount of specialised brake grease (e.g. Copperslip) and reassemble. **N.B.** do not get grease on linings.
- K. **Brake linings** - inspect for thickness and irregular wear (minimum thickness 1.5mm). Replace if necessary, noting position of all parts before stripping down.
- L. **Bowden cables** - check that end fittings in the back plate carrier are undamaged and that inner cable moves freely. If there are any kinks, snags or fraying, replace in pairs. Most modern Bowden cables have self-lubricating linings and therefore do not require separate lubrication. If a grease nipple is fitted, care should be taken not to apply too much, because of the risk that grease will find its way into the back plate and onto the brake linings. **N.B.** if new cables are fitted, it is essential that the handbrake is applied firmly at least ten times after assembly to remove any initial stretch.

- M. **Drum** - Refit brake drum and bearings, replace thrust washer, and tighten the castellated nut until the slack has been taken out. DO NOT over tighten - check with manufacturer's instructions how much torque is required. Back the nut off to the first available slot for the split pin, ensuring that the hub can spin freely. Fit a new split pin. Smear a small amount of grease in the grease cap and refit.
- N. **Unitised bearings** - lightly smear the stub axle thread with oil, refit the drum/bearing unit, fit a NEW flange nut and tighten using a torque wrench to the manufacturer's torque figure. **N.B.** with these units the required torque figures are very high and will require the use of a specialised torque wrench. (AL-KO: 290 Nm/214 lbs Ft ; Ifor Williams: 350 Nm/260 lbs Ft ; Avonride: 280 Nm/200 lbs Ft ) The action of tightening automatically provides the correct adjustment.
- O. **Repeat** - on the other hub units on the trailer.
- P. **Refit** - road wheels and lightly tighten wheel bolts/nuts.

## Brake Adjustments and System Settings

With any overrun braking system the sequence of adjustment is ALWAYS:

**Drum >> Compensator >> Brake Rod >> Coupling**

**N.B.** in the case of over centre handbrakes it is ESSENTIAL that the lever is tied down and the locking pins or stop pegs are fitted as per the manufacturer's instructions BEFORE any adjustment is carried out.

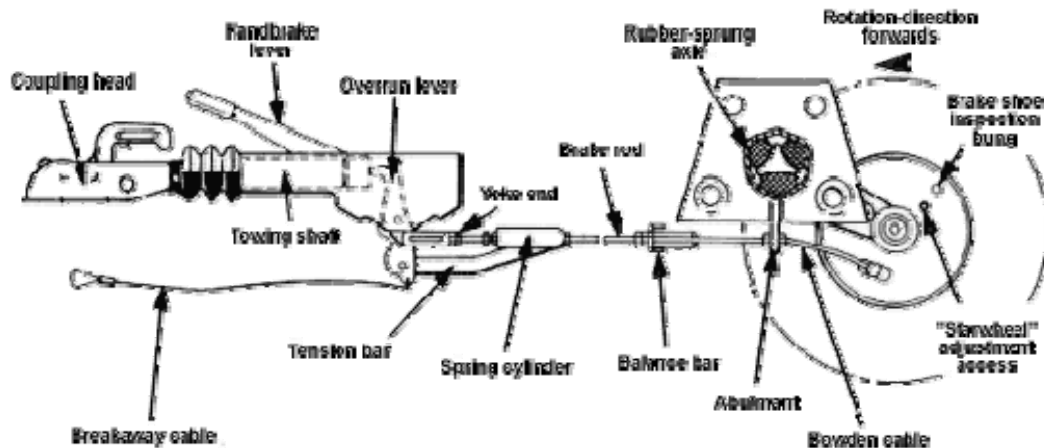

- A. **Before commencing adjustment** - ensure that the handbrake is fully off and that the coupling drawtube is fully extended.
- B. **Linkages** - slacken all nuts.
- C. **Drum** - adjust the linings (AL-KO through the back plate, Knott/Lockheed by the hexagonal nut on outside of back plate), so that resistance can be felt when rotating the drum forwards. Slacken adjuster until drum turns freely in the forward direction. **N.B.** ALWAYS rotate the drum in the FORWARD direction, NEVER in REVERSE, otherwise the auto reverse mechanism will be activated and correct adjustment will be impossible.
- D. **Repeat** - on other brake units on the trailer.
- E. **If an over centre handbrake is fitted** - remove any locking pins or stop pegs, untie the lever. Apply the handbrake three or four times to ensure that brake shoes are centralised. Refit pins or pegs and retie lever down after last application and before proceeding to ( F ) below.
- F. **Anchor plates** - check that the nuts securing outer bowden cable are tight.
- G. **Compensator** - clean off any old grease and dirt. Adjust any slack out of the inner cable, but do NOT put under tension. Check that assembly runs parallel to the axle tube and that nuts and lock nuts are tight. Smear with clean grease.
- H. **Brake rod** - should pass through the centre of the anchor plate by at least 50mm in order to provide correct support. If rod length is excessive, additional support at the front of the trailer will be required. Adjust so that the overrun lever/brakelink just butts up against the rear end of the draw tube shaft. Tighten all lock nuts. **N.B.** this applies to all over centre and gas strut handbrakes and some AL-KO spring cylinder models. Other earlier models from Knott and Bradley, particularly those operating with rods instead of cables, may require some clearance between the draw tube and brake lever - consult the manufacturer's instructions.

- I. **Spring cylinder** - if fitted with a ratchet handbrake adjust the locknuts to give the required clearance. (1mm AL-KO, 3mm Knott, 1-3mm Bradley)
- J. **If fitted with an over centre handbrake** - remove any locking pins or stop pegs and untie the lever.
- K. **Testing** - fully apply the handbrake several times to test its operation. With a ratchet handbrake, the adjustment is correct if slight and equal braking resistance can be felt at each hub when turning the wheels in a forward direction with the handbrake on the second or third tooth. The same applies to gas strut models when the handbrake lever is held manually in position equivalent to first or second tooth. For over centre models apply the handbrake and turn each wheel in the reverse direction until it locks. All brakes should lock firmly. If not, their adjustment is not tight enough and they should be readjusted as per ( C ) above.
- L. **Remove the axle stands and jack** - Check torque settings on wheel bolts. See "Wheel Bolt Tightening" for exact figures and tightening sequence.
- M. **Road test** - if practicable - ensuring that braking is smooth and progressive at various road speeds. (N.B. always carry out brake testing taking due account of other road users. (This is assuming that the tests cannot be carried out on private roads.)

## Fault Finding - Coupling & Brakes

One service problem that has emerged in recent years is the phenomenon of the brake linings sticking fast to the inner surface of the drum. In extreme circumstances if towing the trailer is attempted, the affected hub will not turn and the tyre may be dragged along the ground.

Much investigation has been undertaken by the brake suppliers, but without any concrete conclusions. Although it is believed that the changes in the composition of the lining material in 1989, i.e. The removal of the asbestos content and its replacement with cindered metal, have an influence. Unfortunately it has proved very difficult to exactly reproduce the problems consistently under test conditions, but it is thought that under a combination of some or all conditions, the linings literally bond themselves to the drum, the cindered metal in many cases forming a rust bond. A summary of the conditions and possible remedies is as follows:

- A. Leaving the handbrake on when the trailer is parked for extended periods, particularly in damp conditions e.g. Parked up when damp, parked on long grass. It is essential that when a trailer is to be parked under these circumstances, that the handbrake is left off and the wheels adequately chocked.
- B. Trailers that are infrequently used often suffer most. This could not only be due to the handbrake as above, but also to the fact that the brakes never really are used and properly bedded in. It is vital that such trailers are regularly serviced on a time interval basis - see c) above.
- C. Boat trailers - immersion of the brakes in water, particularly salt water can have serious detrimental effects on the brakes and cause severe bonding problems. Additional servicing is essential - see Boat Trailers - Additional Operating Advice
- D. In the event of one or more brakes sticking on in this fashion, the only remedy is to strip down, clean and reassemble the hub/brake. It may be possible to break the bond by tapping the drum with a hammer after backing off the adjuster. This will enable the trailer to be moved, if stuck in an inconvenient place, but it is essential that the brakes be stripped down as soon as is practicable afterwards.
- E. If all else fails or you experience repeated problems with a particular trailer, consult the Service Department of either the axle or brake manufacturer.

## Fault Finding Table

Fault	Possible Cause	Remedy
Brakes overheat	Wheel brakes over adjusted	Adjust correctly
	Wheel brake dirty/rusty	Clean and re-set
	Handbrake not releasing or left on	Check mechanism and adjust
	Bowden cable(s) kinked	Check and replace
	Drawtube dirty and/or bent	Clean or replace
	Overrun lever/brake lever Sticking and/or bent	Grease or replace
Braking effort weak	Wheel brakes not adjusted	Adjust correctly
	Brake linings glazed or contaminated	Clean or replace and re-set
	Incorrect clearances in system	Check and re-set
	Drawtube dirty and/or bent	Clean or replace
Reversing difficult	Braking system set too tight	Check and re-set
Handbrake weak	Braking system set incorrectly	Check and re-set to eliminate excessive travel
Uneven or jerky braking	Too much play in braking system	Check and re-set
	Worn damper in overrun	Replace
	Faulty components in wheel brake	Check and replace
	Ovality in drum	Check and have skimmed, or replace
	Wheel brakes unevenly adjusted	Check and re-set
	Bowden cable kinked	Check and replace
	Brake linings contaminated	Check and replace
	Excessive nose weight	Check and adjust load
Banging from overrun when braking	Damper resistance completely gone	Replace. Then adjust brakes.
Difficulty coupling and uncoupling	Coupling head mechanism dirty or damaged	Check and clean or replace
	Towball dirty	Clean and, if necessary, grease
	Towball damaged	Check and replace
Excessive play between coupling head and towball	Coupling head worn	Replace
	Towball worn	Replace
Wear in back of eye and rear of pin	Jaw too wide	Check and replace eye
Wear on inside and outside of front of eye	Jaw too tight	Replace with wider jaw
Pin seized in jaw	Jaw crimped by excessive noseweight	Replace jaw and reduce noseweight
Stress fractures on couplings or trailer drawbar	Incorrect eye/jaw combination	Check and replace with compatible components
	Excessive overhang on towing vehicle	Check and discuss with operator. Possibly fit Shocklink
	Mis-match of towing heights	Modify towball or trailer coupling position or fit height adjustable equipment

**N.B.** after any instance of the brakes overheating it is **ESSENTIAL** that the wheel bearings are thoroughly checked over and replaced if necessary.

## NTTA Disclaimer

The information in this guide is intended as a guide. It is as accurate at the time of publication as the editor is able to make it. Neither the Editor nor the NTTA nor any other person or company associated

with the production of this guide accepts any responsibility for any inaccuracies which may be in the text.

It is the responsibility of any person wishing to depend on the facts contained in the NTTA's website to check for themselves with original documentation or any updating regulations, instruments or changes in the law.

### Trailer useful Data information

Coupling – AL-KO160

Overrun device – AL – KO 247661 ETI No:811027

Clamp – AL –KO 249804

Jockey wheel – AL- KO 244538 typ 200 x 50

Wheelbrake type: AL-KO Euro compact 2051 ETI No: 811157 (200mm drum / 51mm shoe) ETI Number on axle plate.

Bearing – AL-KO High Grade Encapsulated Part No: 605124 (34w x 64od x 37id).

Bearings are pressed into break drum and require specialist equipment to remove and fit.

One shot flange nut – Must be changed every time used. - 581200

Useful contacts: AL-KO UK Tel: 01926 818500

[www.al-ko.co.uk](http://www.al-ko.co.uk)



# Operation of the overrun braking system.

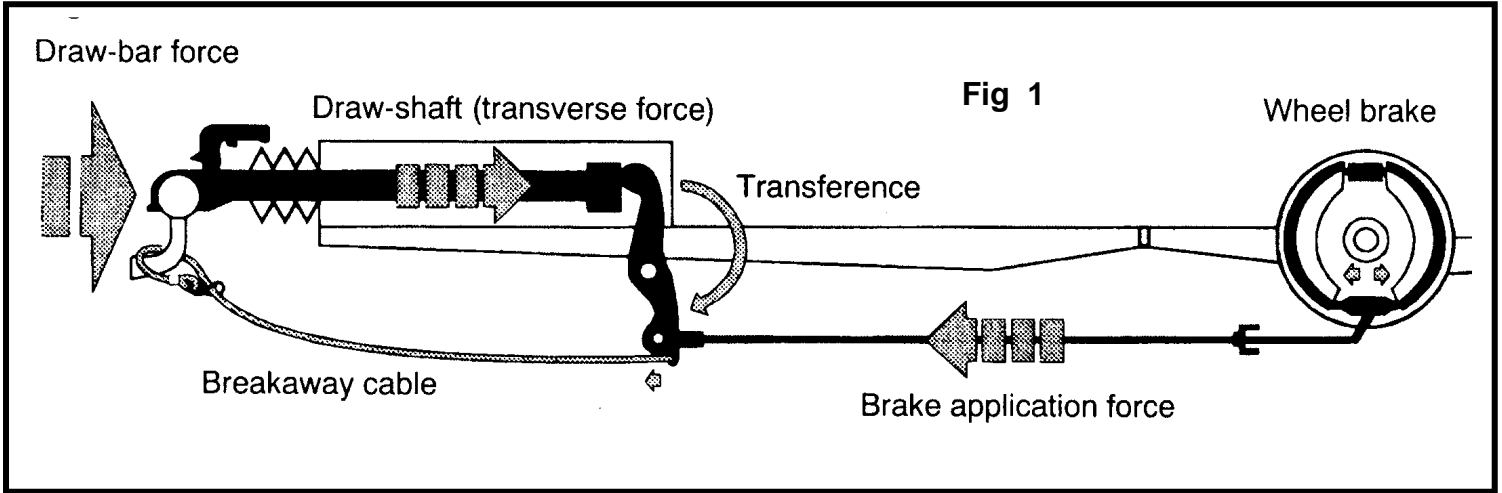

The overrun device can be described as the control device of the overrun brake system. A draw-bar force is produced at the coupling point by reducing the speed of the towing vehicle. After the threshold level has been passed, the draw shaft is pushed in, thus actuating the overrun lever, the wheel brakes (1 & 2) are then applied via the expanding clutch (3) (Fig 2)

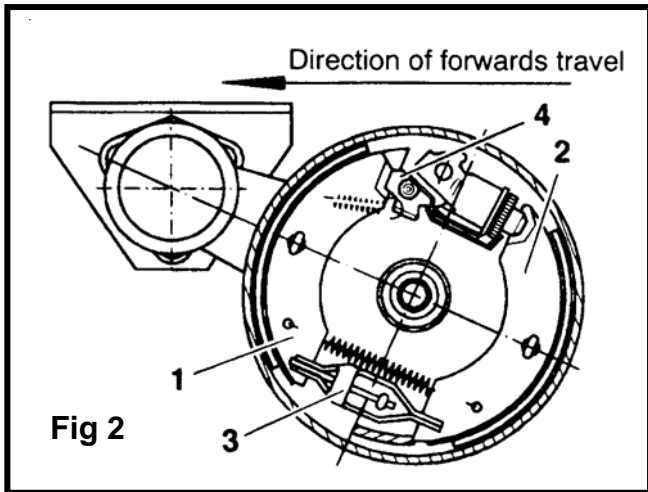

## Reversing.

When reversing, the towing vehicle pushes in the draw shaft of the overrun device. The brake shoes (1,2) are pressed against the brake drum via brake linkage, Bowden cable and expander clutch (3). The brake drum turns backwards, taking the trailing shoe (1) with it. The transmission lever (4) swings back and allows the draw shaft to complete it's full travel. The braking effect is virtually cancelled out and the wheels can revolve freely in reverse (Fig 3).

## Parking.

On the spring cylinder version, engage the handbrake lever right up to the last tooth (90°). On the gas strut handbrake version, pull the handbrake lever over centre. The brake shoes (1 and 2) are pressed against the brake drum by the brake linkage etc. and this applies the trailer brakes.

When the caravan/trailer has been reversed, the brake drum will also rotate backwards. The trailing brake shoe (1) is taken with it and moves the transmission lever (4) back. This lever then pushes the adjuster assembly (5) which in turn pushes the leading brake shoe (2) against the stop (6). The caravan/trailer is then braked.

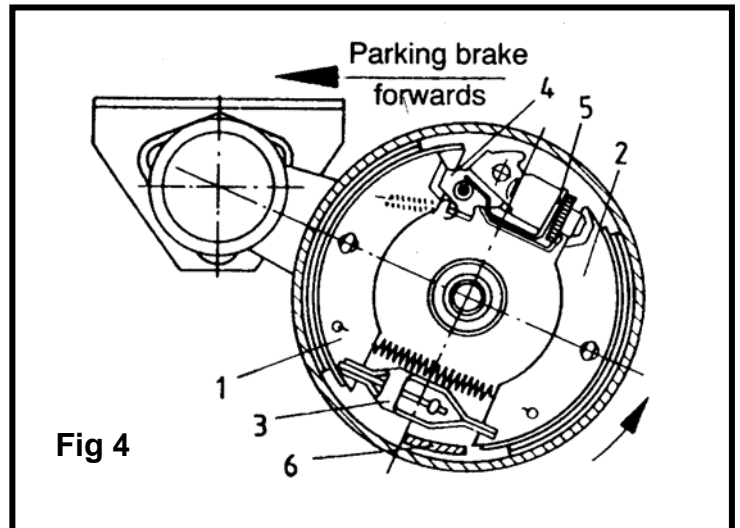
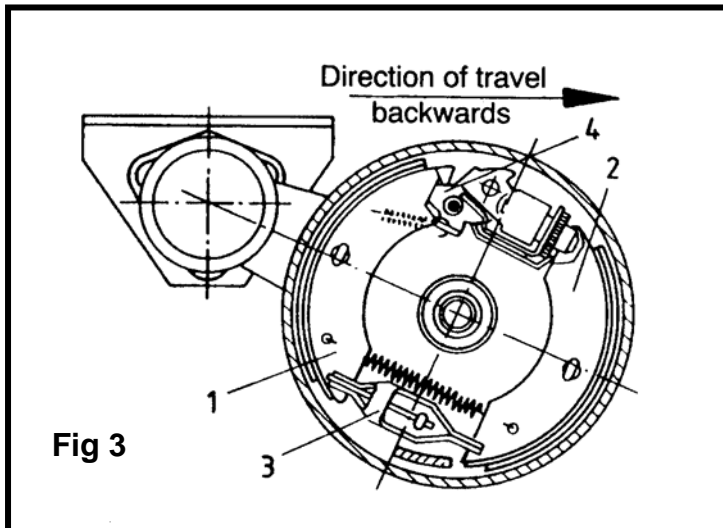
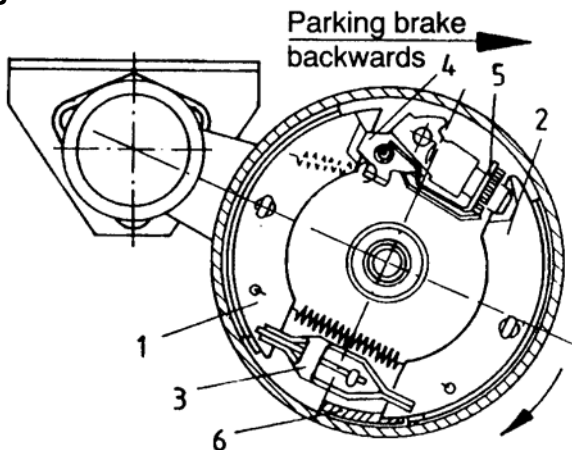
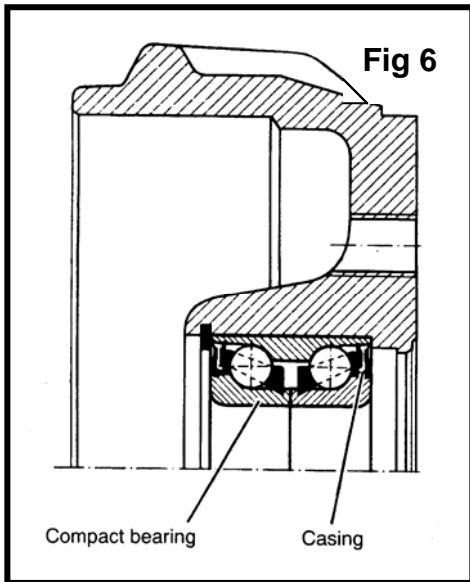

Fig 5



It must be noted that when the handbrake is applied, the vehicle may roll approximately 25 cm (10 inches) backwards before the parking brake force is used to it's fullest extent.

### Wheel Bearing



The wheel bearing is a double-row inclined ball bearing. It has the following advantages over normal bearings.

- No adjustments necessary.
- Easy to maintain (lubricated for life and sealed)
- Protected against dirt ingress (sealed unit)
- Less sensitive to siezure than a taper roller bearing.



The bearing must not be pressed out of the drum as this may damage the bearing and brake drum.

### Adjusting the wheel brakes.

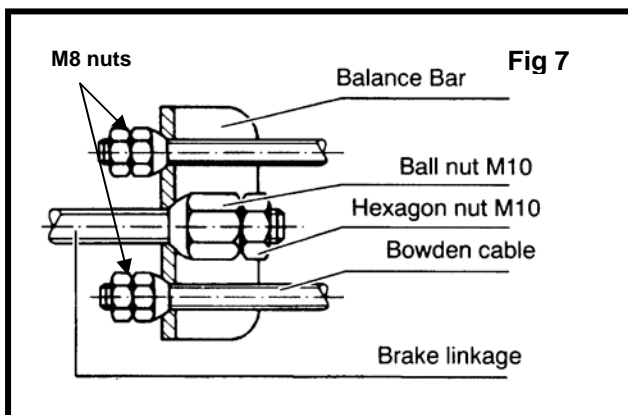

Before adjusting the wheel brakes always rotate the wheel(s) in the forward direction

- Lift the caravan/trailer using a suitable jack.
- Ensure the coupling head and overrun shaft are fully extended.
- Release the handbrake completely.
- Release the brake linkage from the balance bar(Fig 7)
- On newer models the M8 nuts are quick fit nipples.
- Check the free play in the wheel brake.

The free play should be as uniform as possible for 2 or 4 wheel brakes respectively.

Nominal : 4 - 6mm on single axles.

6 - 8mm on tandem axles.

Measured on the inner cable where attached to the axle abutment bracket .

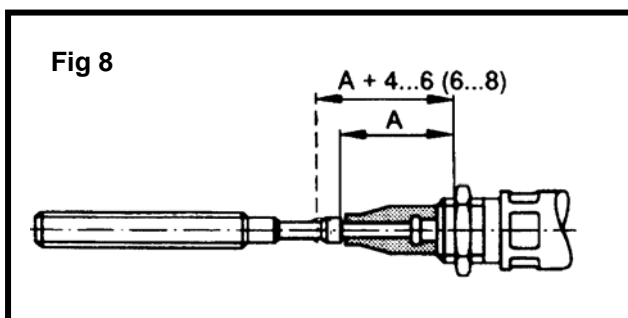

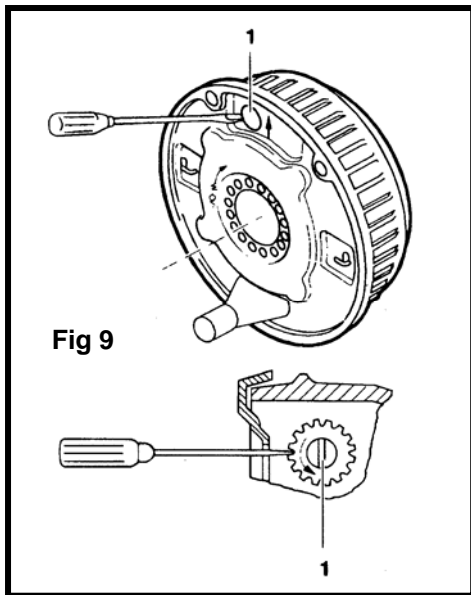

- Only ever set or adjust the wheel brake by means of the adjuster screw (1)(Fig 9). Adjust in the direction of the arrow, and release against the direction of the arrow.
- Reconnect the brake linkage to the balance bar, and apply the handbrake hard several times, to allow the braking adjustment to settle.

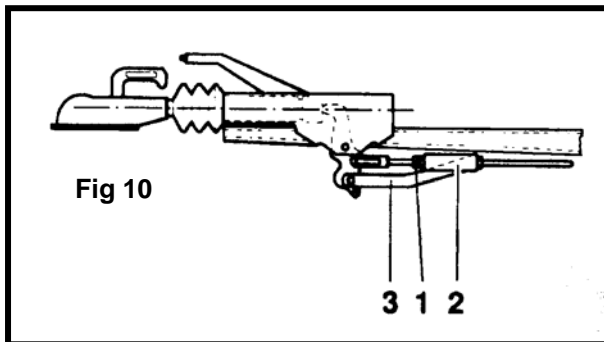

- On the spring cylinder type (2), adjust the locking nuts M10 (1)(Fig 10) to allow 1mm of free play between the nut and the spring cylinder. The cylinder should be able to rotate freely but not slide on the brakerod.  
**N.B** On some chassis the locking nuts are replaced with a single Nyloc nut.

#### Check the setting

- Apply the handbrake lever up to the first or second tooth, and check that there is equal braking resistance on each wheel.
- On the gas strut version the handbrake lever has to be held on the first tooth manually.



**When adjusting the wheel brake, only turn the wheels in a forward direction so that reverse mode is not actuated.**

## Servicing the wheel brakes.

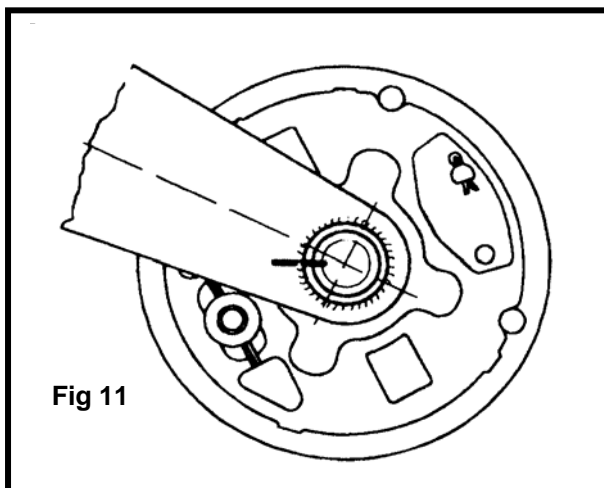

#### Dismantling the brake drum.

- Remove the wheel and tyre.
- Mark the position of the plastic cap on the swing arm with a felt tip pen so that any movement on the stub axle can be detected (Fig 11)



**If the stub axle or back nut are moved this will alter the toe-in and camber . Should such movement take place the axle should be removed and returned to AL-KO to be realigned.**

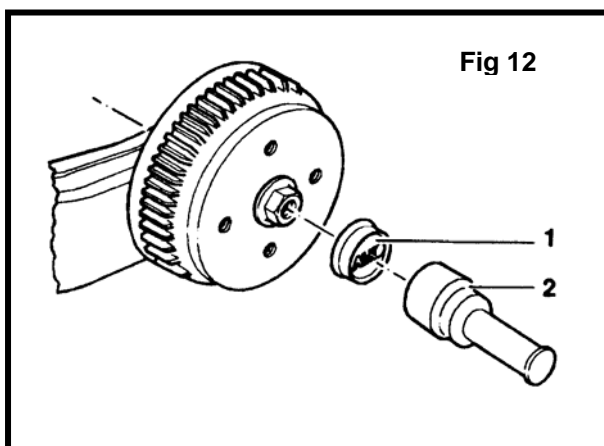

- Remove dust cap with Former Tool (603751).
- Unscrew the flange nut. **Always use a new nut when refitting.**
- Before fitting new nut apply a small amount of mineral grease (800052) to the stub axle thread.
- Release the handbrake and remove the drum.
- Replace worn or corroded brake drums.



**Note the torque setting (290Nm +/- 10Nm).**

**Brake drums must not be reskimmed.**

## Visual checks.

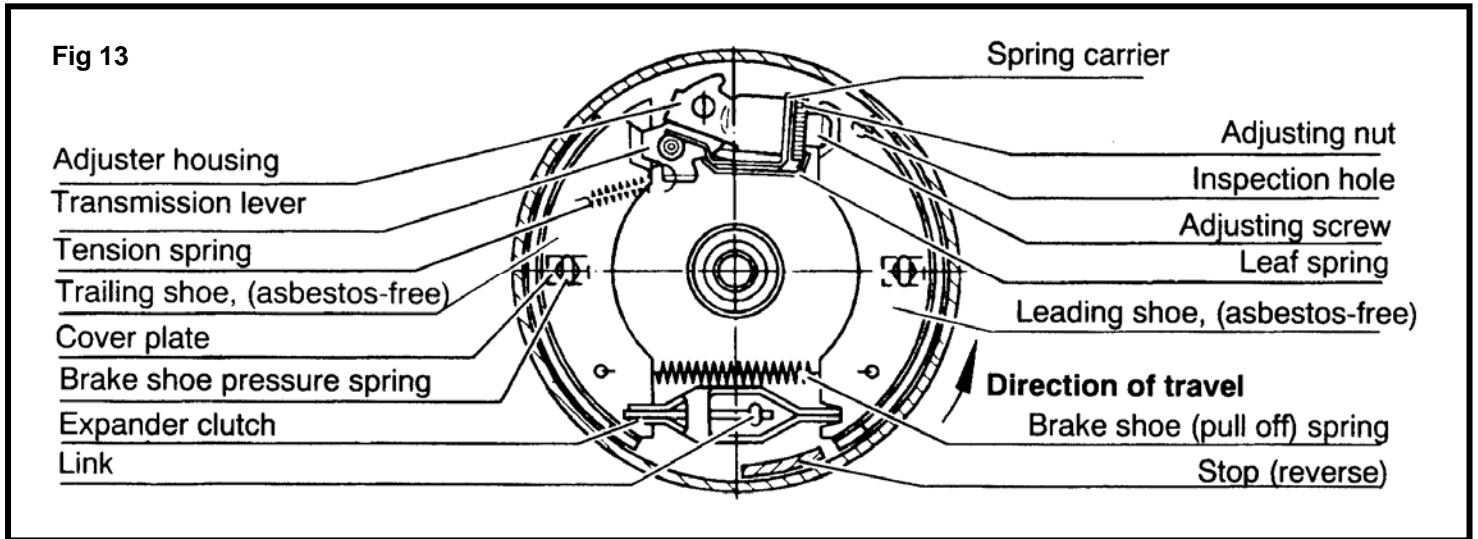

### Check the condition of the brake shoes.

The wear on the shoes is greatest where the inspection hole is located on the backplate. The leading shoe usually wears faster than the trailing shoe.



**Always replace brake shoes as a pair.**

- Check that the expander clutch, adjuster nut and transmission lever are lubricated and running smoothly (use Molybdenum Disulphide grease).
- Check the tension on the leaf spring and that the adjusting nut is engaged onto the brakeshoe.
- Check the pressure of the brakeshoe retaining springs.

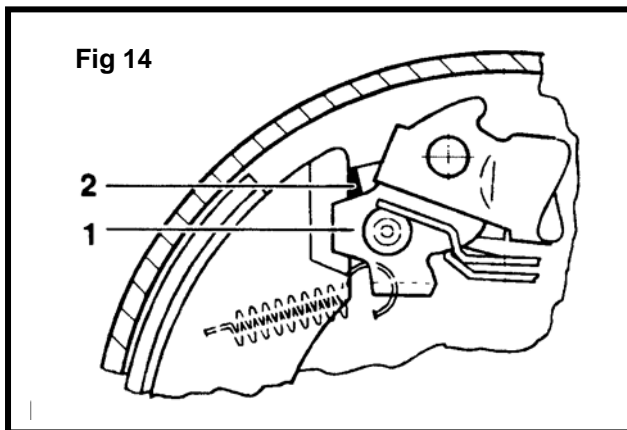

- Transmission lever (1) must abut the adjuster housing stop (2).

- If any parts are to be removed from the wheel brake the Bowden cable must be unhooked from the expander clutch.
- Replace brakeshoes where linings are less than 2mm thickness.
- If replacing pressure springs also replace cover plates.
- On type 1637, the left and right shoes are different. The embossed markings (see arrows Fig 15) must be followed.



**If the shoes are fitted to the wrong side the brake will not function.**

- 2051 and 2361 brake shoes are **NOT** handed.

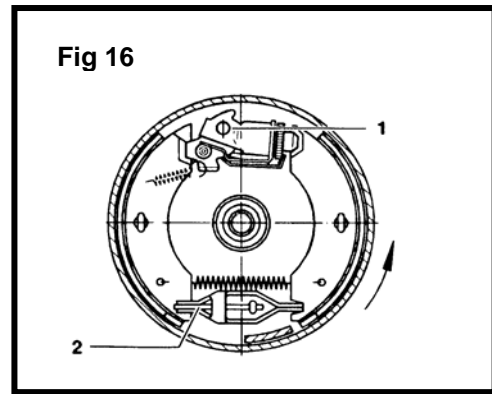
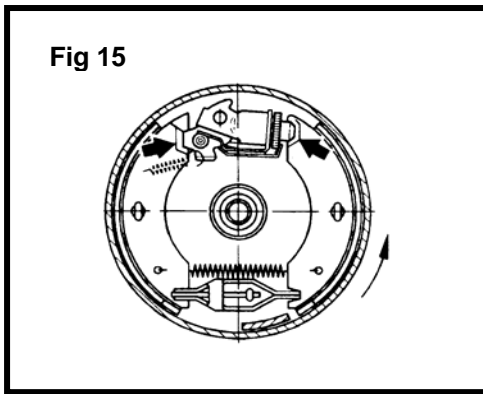

## Expanding clutch.

- Lubricate expander pivot points.
- Replace corroded expanders.
- **N.B** Note the correct position for fitting:  
Expander lever pivot arm (2) to transmission lever pivot bolt (1). These points **must always** be on the same side (Fig 16).

## Return springs.

- Replace relaxed or damaged return (pull off) springs.

## Transmission lever.

- Lubricate pivot points.
- Replace corroded or damaged levers and pivot bolts.
- If the lever does not abut the adjuster housing stop , replace extension spring (Fig 14).

## Adjusting assembly.

- Lubricate adjusting nuts.
- Unscrew the adjuster screw and lubricate the thread.
- Replace corroded or damaged screws or nuts.

## Leaf springs (adjuster housing).

- Replace corroded or relaxed leaf springs.

**N.B** The adjuster screw,nut and leaf spring are only supplied as a complete assembly.

Part No.s are as follows:

1637 Brakes - 387706  
 2051 Brakes - 387323  
 2361 Brakes - 387323



**All METAL friction points, NOT BRAKE PADS, on the wheel brake must be lubricated with Molybdenum Disulphide Grease ( AL-KO Part No. 800098 )**



Tel: 01926 818500  
 Fax: 01926 818562  
 email: vtsales@al-ko.co.uk  
 www.al-ko.co.uk

**AL-KO KOBER LIMITED**  
 South Warwickshire Business Park  
 Kineton Road  
 Southam  
 Warwickshire  
 CV47 0AL

**ETI No: 811027**  
**161S Delta Overrun Assembly With Gas Strut**  
**Handbrake**

1<sup>st</sup> Issue Date: 01.05.99  
 Date of Last Mod: 03.07.03  
 Issue Level: D  
 Comments:

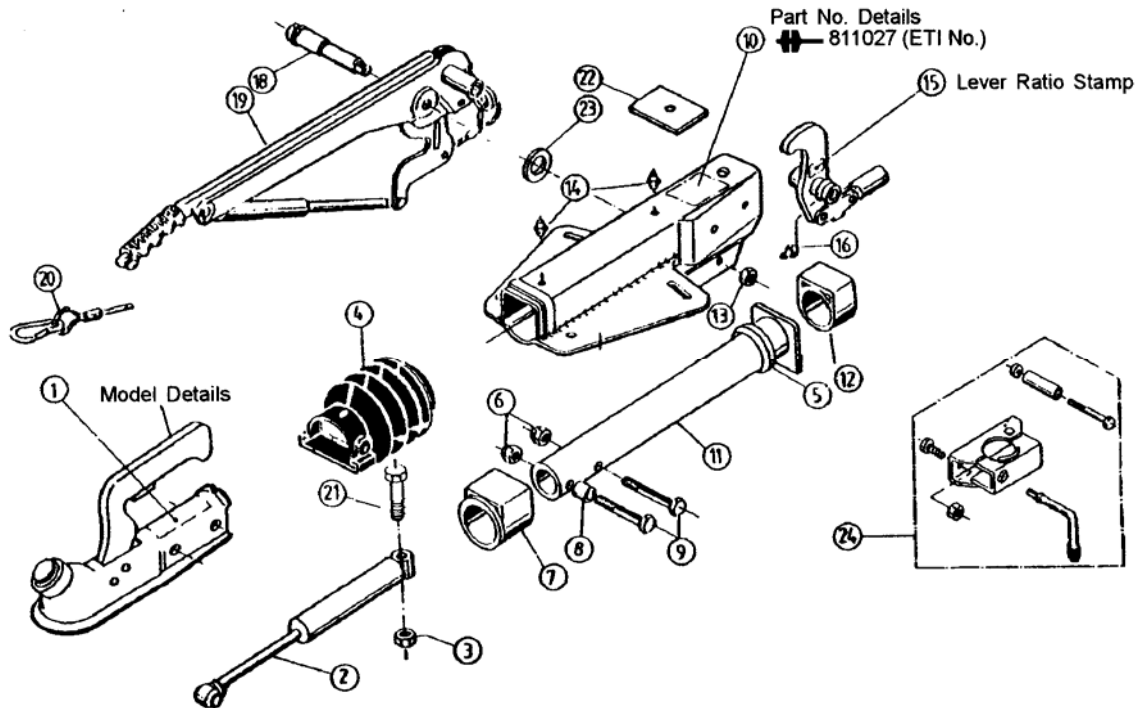

© AL-KO KOBER Ltd 2003

Item	Description	AL-KO Item No.	Item	Description	AL-KO Item No.
1	Coupling Head (50mm)	Quote Model	16	Grease Nipple AM6 (Included in Item 15)	700203
2	Damper	370556	18	Handbrake Pivot Bolt	581145
3	Hexagon Nut M12 DIN 985 – 10 A3	702750	19	Handbrake Assembly (includes Burst Ring Item 17 & Breakaway Cable Item 20)	220096
4	Gaiter	366356	20	Breakaway Cable	368605
5	Bump Rubber	371372	21	Hexagon Bolt M12 x 90 DIN 931	700312
6	Hexagon Nut M12 DIN 985 – 10A3C	702750	22	Reinforcement Plate	581699
7	Front Bearing Bush (Not Reamed)	353943	23	Washer 19.2 x 34 x 3 DIN 125	370693
8	Spacer	370559	24	Jockey Wheel Clamp Kit Complete: Pressed Steel Clamp (Illustrated) Cast Clamp (Not Illustrated)	293020 285750
9	Hexagon Bolt M12 x 70 – for AK160 for AK300 for AK350	700061 701959 702823			
10	Housing Complete with Bearings	Quote Part No & ETI No.			
11	Overrun Shaft	571873			
12	Rear Bearing Bush (Not Reamed)	353942			
13	Hexagon Nut M12 DIN 985 – 10 A3	702750			
14	Grease Nipple AM 8 x 1	2171710001			
15	Overrun Lever:				
	Lever Stamped 27	380265			
	Lever Stamped 30	380285			

**ETI No: 811157**  
**Compact Wheelbrake 2051 up to 1350 Kg (Aa)**

1<sup>st</sup> Issue Date:  
 Date of Last Mod: 20.05.04  
 Issue Level: B  
 Comments:

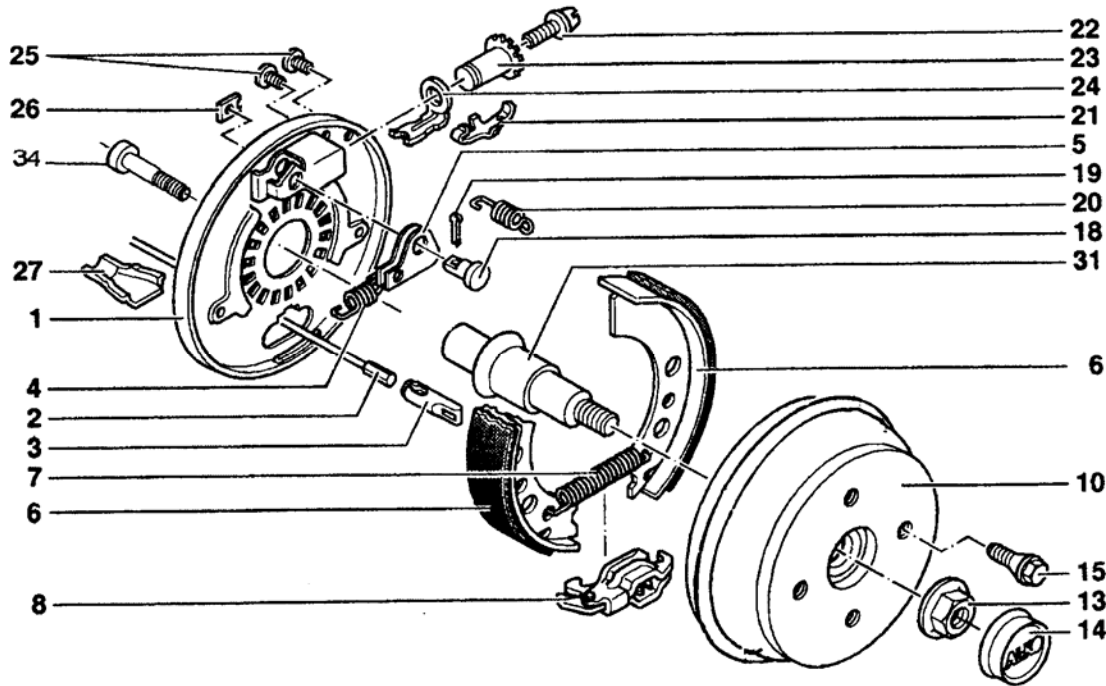

© AL-KO KOBER Ltd 2004

Item	Description	AL-KO Item No.	Item	Description	AL-KO Item No.
1	Backplate Welded LH	571376*	13	Flange Nut	581200+
	Backplate Welded RH	571377*	14	Dust Cap	581197+
2	Detachable Bowden Cable		15	Wheelbolt :	2081670018
	Outer Cable Length:			Conical M12 x 1.5	2081670020
	350 mm	247281		Spherical M12 x 1.5	372138
	530 mm	247282		Spherical M14 x 1.5	368651
	770 mm	247283	18	Bearing Bolt	700192
	890 mm	247284	19	Split Pin 4 x 20 – DIN 94	2088800003+
	1020 mm	247285	20	Shoe Retaining Spring	
	1130 mm	247286	21		
	1320 mm	247287	22	Adjuster Assembly Complete.	387706
	1430 mm	247288	23		
	1620 mm	247289	24		
	1790 mm	247290	25	Plastic Plug	373245
3	Cable Eye	604262	26	Cover Plate	2382610002+
	Pressed Version		27	Bowden cable Shell	371387
4	Reverse Lever Spring	2187370003	31	Stub axle	605119*
5	Reverse Lever LH	571386	34	Bolt (Single Use Only) M20 x 60 DIN	704096
	Reverse Lever RH	571387			
6	Brake Shoe ( Pair includes Item 16)	ECS-BRCMP02			
7	Pull-off Spring	2082000007			
8	Expanding Clutch	571510			
10	Brake Drum Complete:				
	98 x 4/M12 x 1.5	623111			
	100 x 4/M12 x 1.5	623112			
	112 x 5/M12 x 1.5	623113			

\* Not available as spare item.  
 Please consult AL-KO Service.

+ Included with ECS-BRCMP02 (item 6)